

Lubricant Analysis Using MAINTelligence Monitor

Introducing the VIP Oil Analyzer

MAINTelligence Monitor, already your best choice for lubrication analysis software, is made even better by the addition of a direct interface to the **VIP Oil Analyzer**, a state-of-the-art on-site lubricant screening instrument.

The **VIP Oil Analyzer** is capable of measuring contamination level, ferrous particle level and fluid viscosity with a single sample. It is the only instrument capable of simultaneously measuring these three critical parameters. An operator can analyze up to fifteen samples per hour with a single instrument—the **VIP Oil Analyzer** is both fast and easy to use.

The **VIP Oil Analyzer** uses a computer-controlled pump to ensure constant flow, making it the most repeatable field instrument available.

The **VIP Oil Analyzer** has an easy-to-use interface with **MAINTelligence Monitor**.



Use **MAINTelligence Monitor** and the **VIP Oil Analyzer** to manage your on-site oil analysis program, and, at the same time, use **MAINTelligence Monitor** to access data from your oil analysis laboratory of choice. Your on-site analysis and lab analysis results combined in a single package!

On-Site Oil Analysis — The Key Benefits

Oil analysis has long been an important part of machine condition monitoring. In the past, analysis has largely been confined to sending samples to an outside laboratory, with the inevitable delay in results.

In the last few years, operators have been turning to on-site analysis. On-site oil analysis has the immediate benefit of producing more timely results.

On-site oil analysis is an integral part of an effective contamination control program. Lubricant technicians are able to set lubricant

cleanliness targets and to monitor the effect of changes designed to improve those levels—without the difficulty and expense of sending samples to a commercial laboratory.

Other Advantages of on-site oil analysis

1. Ensures Proactive Management of Lubricants and the Lubrication Process.
2. Develops Effective Predictive Maintenance and Troubleshooting Techniques.
3. Increases the Acceptance of Lubricant Management within the Organization.

How the VIP Oil Analyzer works...

The sample of oil or hydraulic fluid is pushed through the filter assembly at constant flow with a computer controlled syringe pump driver.

A pressure transducer continuously measures the pressure while a magnetic flux sensor measures the buildup of ferrous wear particles. These measurements are converted to viscosity, metallic iron wear particle concentration and particle contamination.

A temperature sensor in the fluid stream allows the system to convert the viscosity to a standard temperature. The results are displayed and stored in the computer.

The **VIP Oil Analyzer** uses a unique FIRON™ filter containing a matrix of ferromagnetic fibers. These fibers become magnetized when the filter is placed in the analyzer head. When an oil sample is drawn through, metallic iron particles are attracted to these fibers and captured. The VIP Analyzer displays the magnetic equivalent in milligrams per litre.

The filter captures non-magnetic particles larger than the spacing between fibers. Both magnetic

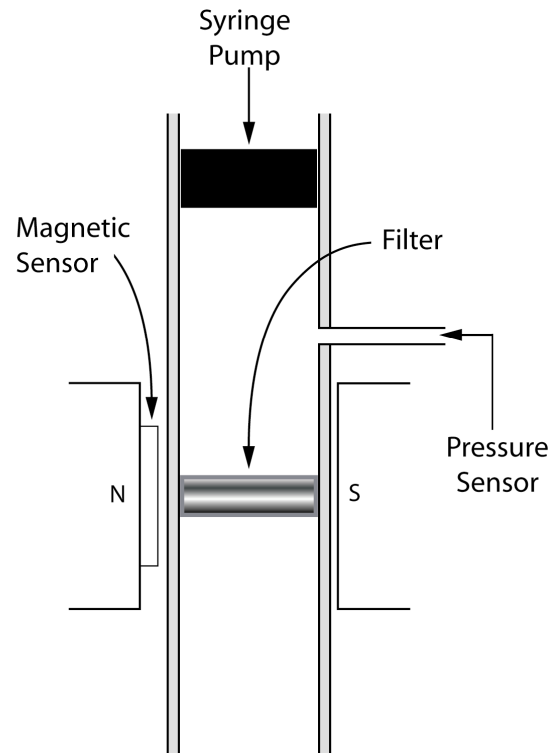

and non-magnetic particles can be recovered for microscopic analysis when the filter is removed and backwashed. This cleans the filter for reuse.

MAINTelligence Monitor—Lubricant Analysis Features

With an extensive library of lubricant data and a wide range of lubricant test types, **MAINTelligence Monitor** is the perfect tool for one of the key processes in condition monitoring - lubricant analysis.

Some features of **MAINTelligence Monitor**:

- Handles all ASTM tests
- ICP and rotating disk spectrography,
- FTIR, RUL and other physical properties tests.
- Particle counts (ISO/NAS), including the new 4µm/6µm/14µm standard.
- Analytical ferrography and photomicrography, including image data.
- Sample Label Generation and Sample Number Tracking (Bar Code Enabled)
- “One-button” access (through the Internet) to many oil analysis laboratories.
- Optional interface to the Condition Assessment module for automated diagnosis of laboratory results.



Design Maintenance Systems Inc.
340 Brooksbank Avenue, Suite 100
North Vancouver, BC, Canada
(604) 984 3674 <http://www.desmaint.com>

VIP Oil Analyzer Specifications

Technical Specifications

Data Outputs

Particulate:	Reports ISO 4406 Codes; NAS 1638 Codes; Solids Concentration In Mg/L.
Viscosity:	Reports CP @ Test Temp; Cst @ 40; Cst @ 100 and Fluid Temp.
Magnetic Iron Concentration:	Reports Magnetic Iron Concentration In Mg/L.

Data Validity

Consistency:	Viscosity +/- 3% of mean; Particulate +/- ICode level dependent on sample handling. Magnetic Iron +/- 10% based on uniform distribution.
Accuracy:	+/- 6% utilizing correct calibration procedures.

Calibration

Particulate:	Calibrates per ISO 4402 – Utilizing a pre-measured dust standard.
Viscosity:	Calibrated with new oil, Verified with Viscosity standard.

Test Parameters

Fluid Temp:	Room temperature, Not to exceed 75°C.
Viscosity Range:	10 Cst @ 40 To 680 Cst @ 40
Test Duration:	3 Minutes to run, excluding sample handling.
Sample Volume:	10 ml. Per Test Run

Physical Attributes

Operation:	Run through MAINTelligence Software, Direct interface.
Power:	100-240 VAC, 50/60 Hz, Specified when ordered.
Communications:	9 pin RS-232
Weight:	16 lb (7.5 kg)
Size:	10 in (height) x 10 in (length) x 13 in (width) (25 cm x 25 cm x 32.5 cm)



Design Maintenance Systems Inc.
340 Brooksbank Avenue, Suite 100
North Vancouver, BC, Canada
(604) 984 3674 <http://www.desmaint.com>